

Garmin®

**MARINE
INSTRUMENTS**



Digital Depth Sounder

(Flush Mounted, Remotely Switched)

- Depth in Feet, Meter, or Fathoms
- Shallow or Deep Water Alarms
- Alarms are Audio and Visual
- Keel Offset
- Trip Log

Owner's Manual

IS0141A

ECR#2947 10/2002

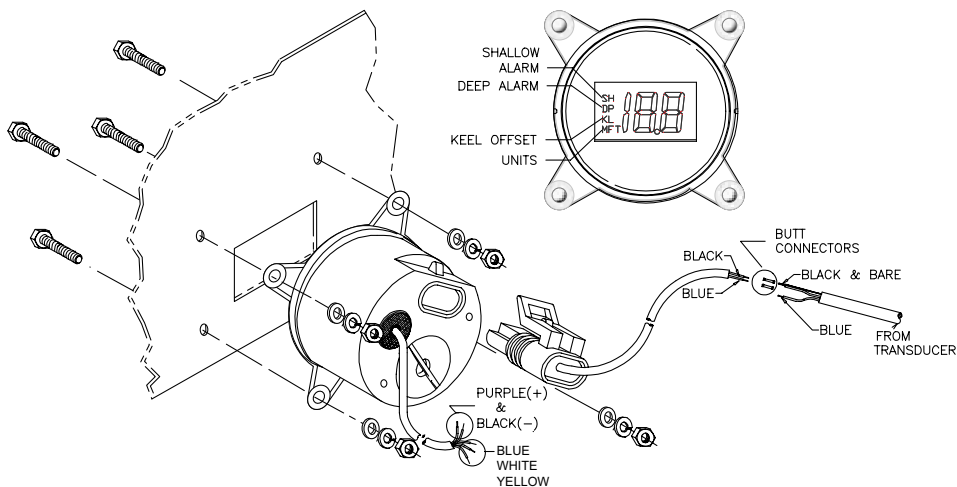

WARNING: The depth sounder is not to be used for navigation or as a device to avoid grounding which may result in boat damage or personal injury. Always use caution operating in shallow areas and maintain a very slow speed. Be aware that depths may change too quickly for you to react and avoid grounding.

CAUTION: Disconnect the battery during installation. Tighten nuts on the clamp only slightly more than you can tighten with your fingers. Six **inch-pounds** of torque are sufficient. Over-tightening could result in damage to the instrument and may void your warranty.

1. It is recommended that insulated wire terminals, preferably ring type, be used on all connections to the power source.
2. Connect the black wire to the boat's electrical ground, usually available at several locations near the instrument panel.
3. Connect the purple wire to a 12 Volt DC circuit that is activated by the ignition switch.
4. Follow the enclosed Airmar Technology Corporation instructions for

installing the transducer with the adhesive supplied.

5. Once the transducer is installed and you have lead the cable to the depth sounder, connect the three wires (black, blue, and bare) from the transducer to the corresponding colored wires of the connector plug using the butt connectors supplied. (See Illustration)

NOTE: The bare and black wire from the transducer will need to be twisted together and then both connected to the black wire of the plug.

The butt connectors have a heat activated waterproofing. When the butt connections have been crimped, slowly apply heat with a heat gun until you see sealant coming out of the connector ends. It is recommended to wrap the connections together with electrical tape for further protection. Plug the connector into the rear of the depth sounder.

NOTE: If the transducer cable is not connected properly or not plugged into the depth sounder, the display will blink when the power is applied to the unit.

NOTE: The remote switch must connect to a good ground. It is recommended that a ground wire be run from the switch ground connection to the Depth Sounder ground connection at the Depth Sounder.

Wire Color	Function
Black	Ground (-)
Purple	Ignition (+)
Blue	Mode Switch
White	Up Switch
Yellow	Not Used

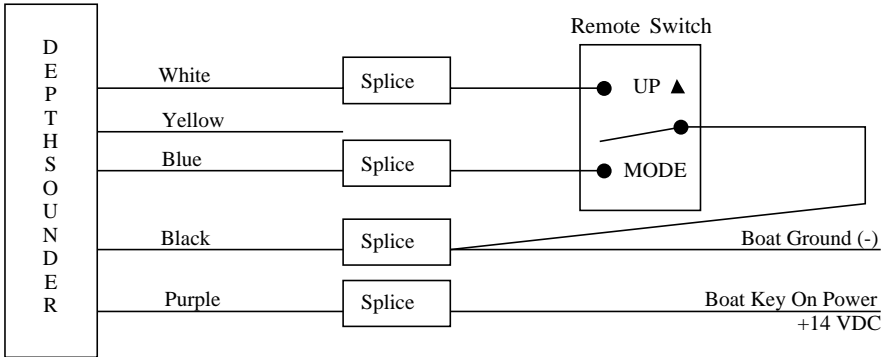

General description:

1. The depth sounder will read to 199 feet or the corresponding number of meters or fathoms. If the reading is less than 19.9 feet, meters or fathoms, 1/10th increments will be displayed. If the reading is more than 19.9 feet, all readings will be in whole numbers.

2. The depth sounder has an audible and LCD displayed depth alarm with adjustable shallow and deep limits and a depth below keel offset feature. These settings once made are stored in memory and will remain even if the battery is disconnected.

Operation:

1. Power on. The depth sounder will activate automatically when the power to it is initially turned on.

You do not have to press the toggle switch down. The LCD will illuminate showing the depth and will also show the type of units selected, feet (FT),

meters (M), or fathoms (F). To turn the depth sounder off, press and hold the toggle switch down for 4 seconds. Pressing the toggle switch down again will reactivate the unit.

NOTE: The instrument is designed to have the internal LED lighting remain on as long as power is supplied even if the unit is turned “off” at the keypad.

2. Depth alarm.

Shallow mode: Pressing the toggle switch down again displays the “SH” shallow depth alarm setting. This is the shallowest water that will activate the alarm. Press and hold the toggle switch up to adjust the reading to the desired depth.

Deep mode: Pressing the toggle switch down again displays the “DP” deep depth alarm setting. This is the deepest water that will activate the alarm. Press and hold the toggle switch up to adjust the reading to the desired depth. When

the shallow depth setting is read by the depth sounder, the “SH” will flash on the LCD and the audible alarm will sound rapidly. When the deep depth setting is read by the depth sounder, the “DP” will flash on the LCD and the audible alarm will sound at 2 beeps per second.

NOTE: To fully deactivate an alarm, reset it to zero. Pressing the toggle switch down temporarily deactivates the alarm. To reactivate the alarm press the toggle switch down until the depth reading appears.

3. Keel offset. Pressing the toggle switch down again displays the “KL” keel offset setting. This can be set so that the depth sounder either shows the depth below the keel or the depth below the transducer. Press the toggle switch up to adjust the reading to the desired

depth no more than 19.9 ft. For example if the bottom of the keel is 2ft below the transducer and you want the depth sounder to read the depth below the keel, the display should be adjusted to read 2.0 FT.

NOTE: Once a keel offset is programmed, the shallow and deep alarms will be activated by the depth below the keel.

4. Units. Pressing the toggle switch down again displays “Un” on the LCD indicating the units mode. Press the toggle switch up to set the units desired to feet (FT), meters (M), or fathoms (F). These units once set, will remain the same for all modes. Pressing the toggle switch down again returns the depth sounder to normal operation.